

LED HIGH-LITE



LED Light^{ing}

Technical specification

LED Lighting

- Uses the Latest LED technology making the units more energy efficient and cost effective compared to fluorescent tubes.
- IP65 waterproof LEDs, with a 50,000 hour life span.
- 6000 - 6500K pure white LEDs or 3000K warm white LED range with a 120° beam angle.
- 60 LEDs per metre.
- 24V - 14.4W per metre power consumption.
- 2 year warranty.
- Full CE certification and ROHS complaint.

Drivers

- Fully encapsulated, IP67 rated, waterproof driver.
- Constant voltage (24V)
- Short circuit/ Overload/ Over voltage/ Over temperature protection
- Full CE certification and ROHS compliant.

LED High-lite fittings

- Designed in house with a slim, 50mm diameter aluminium extrusion.
- Supplied in your chosen size.
- Aluminium end caps.
- 300mm brackets.
- Polycarbonate lens diffuser.
- 2 year parts warranty.

LED High-lite options

- Black or white painted as standard
- Pure or Warm LEDs as standard
- Non-standard RAL colours available upon request
- Non-standard brackets available on request
- Photo electrical cell switches

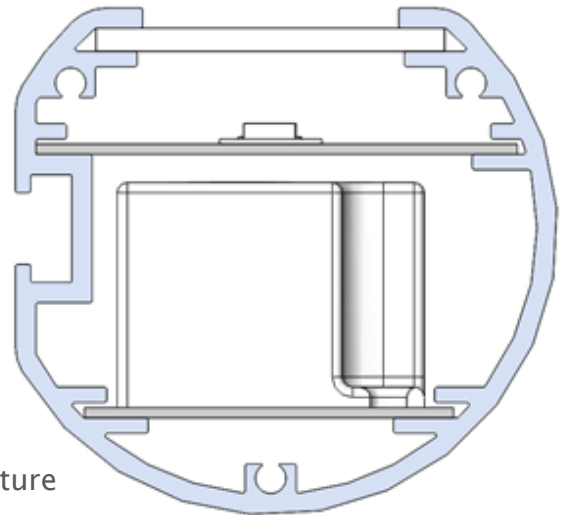

50mm diameter

T: 01842 766677
E: sales@dmuk.co.uk
W: www.druk.co.uk

Display Manufacturing UK LTD
(DMUK LTD)
36 Howlett Way
Fison Industrial Estate
Thetford
Norfolk
IP24 1HZ